

Aug 2024

Click the button
to watch the
assembly video

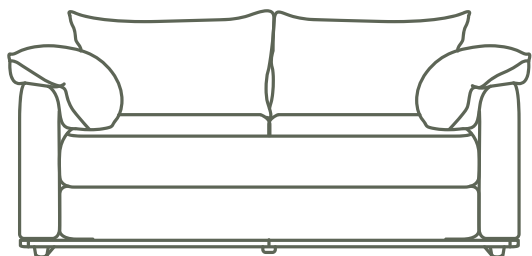

KOALA SOFA BED

koala

What's in the box*:

*Not to scale

Click the button
to watch the
assembly video



x6
Long Leg



x3 / x1
Queen Double / Single
Short Leg



x1
Baseboard Connector

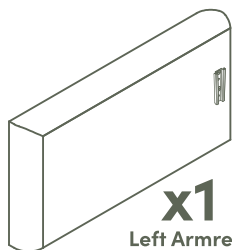

x1
Left Armrest

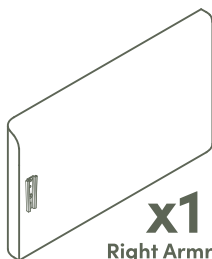

x1
Right Armrest

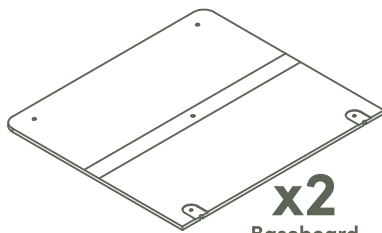

x2
Baseboard

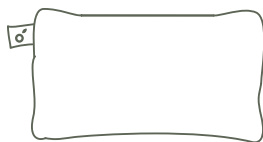

x2/x1
Queen Double/Single
Backrest Cushion

x1
Backrest

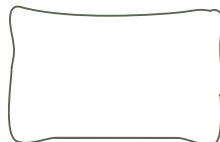
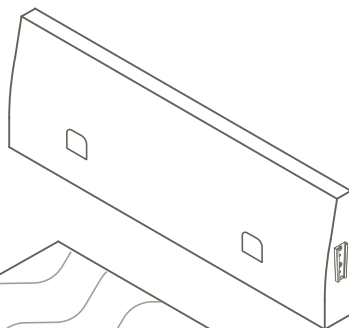

x2
Armrest Cushion

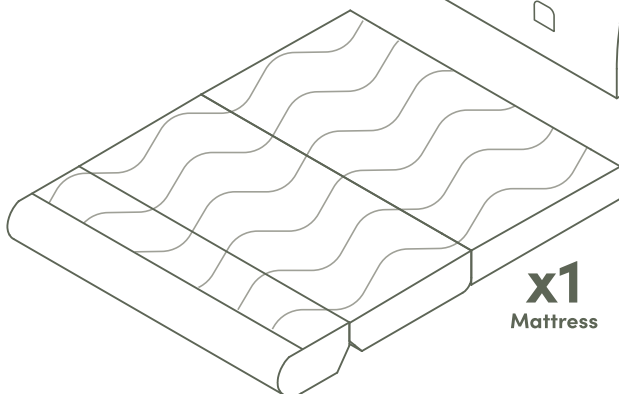

x1
Mattress



NOTE - Open the seat cushion box first.
Due to compression, max comfort reached after
3-5 days.

- 1.** Connect the two arms to the backrest using the wedge brackets.

Click the button to watch the assembly video

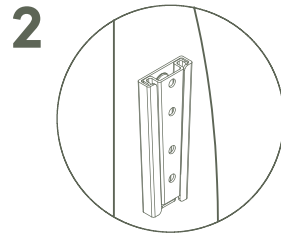
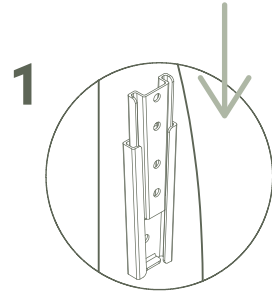
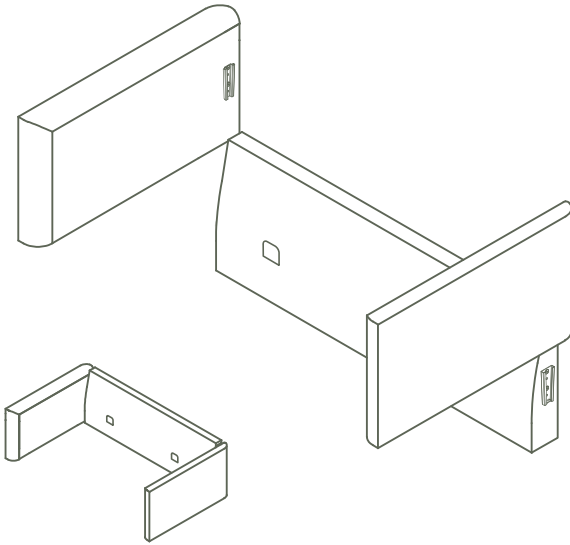

- 2.** Ensure sofa bed is positioned away from walls and carefully rotate the sofa bed on its back.

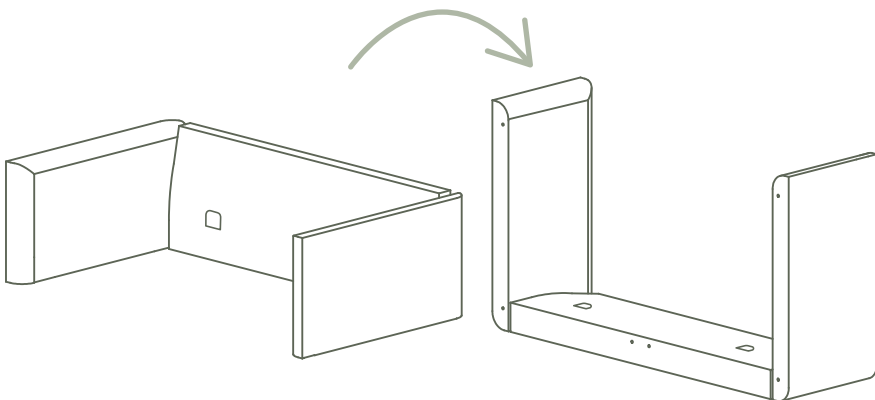

- 3.** Screw baseboard with the velcro facing in, onto frame using the longer length thread legs in the order shown.

Click the button
to watch the
assembly video



x3



1st

2nd

3rd

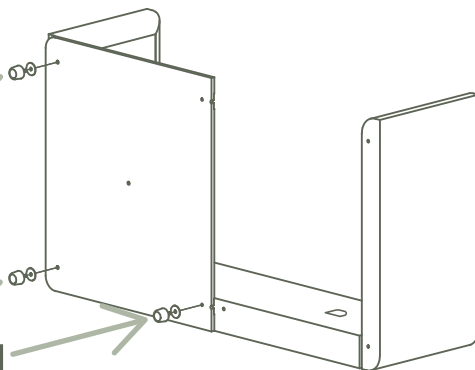

NOTE - Use coloured stickers
on armrest and backrest as
alignment guide.

- 4.** Screw second baseboard with the velcro facing in, onto frame using the longer length thread legs in the order shown.



x3



1st

3rd

2nd

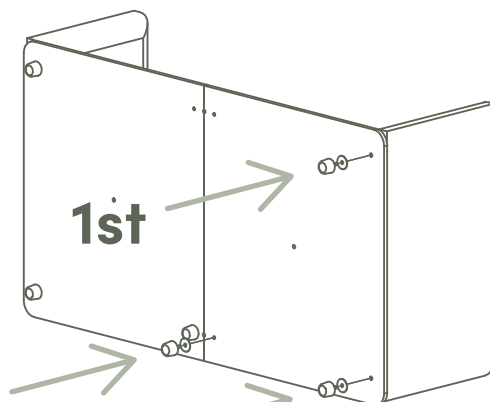

NOTE - Use coloured stickers
on armrest and backrest as
alignment guide.

5. Screw in connector plate using the shorter length thread leg.

Click the button to watch the assembly video



x1



x1

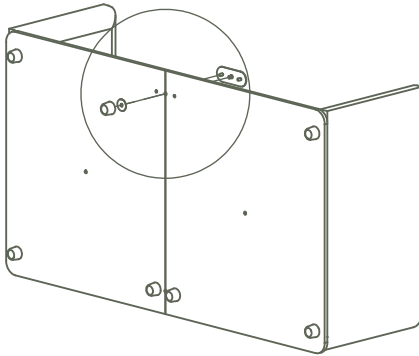

1

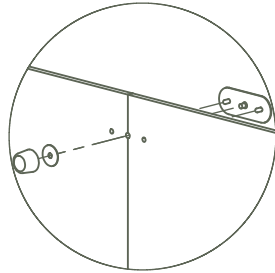

2

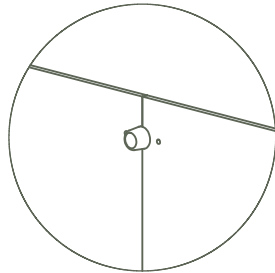

6. Screw shorter thread legs into baseboard.



x2

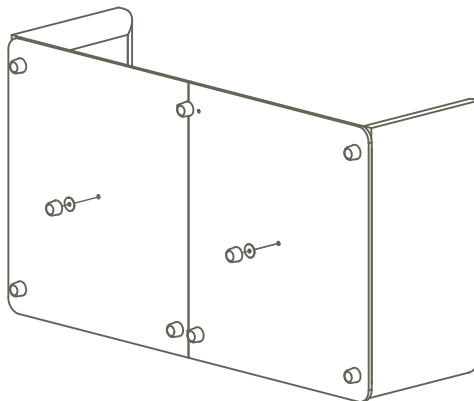

HEADS UP!
Your single Cushy Sofa Bed
does not require middle legs!

7. Carefully lower the sofa bed on its legs.

Click the button
to watch the
assembly video

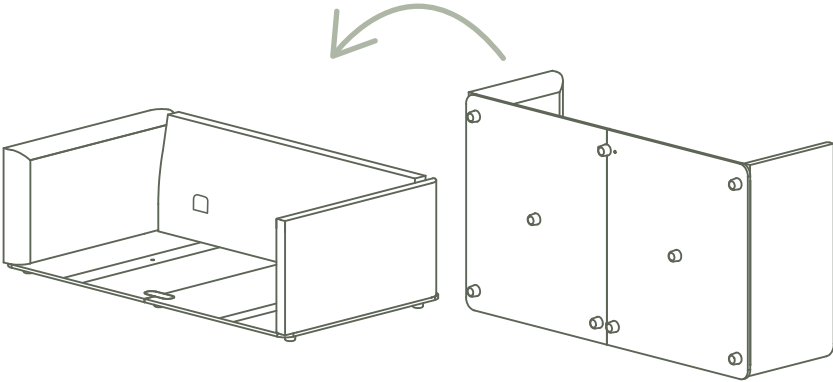

8. Attach mattress to frame using velcro.

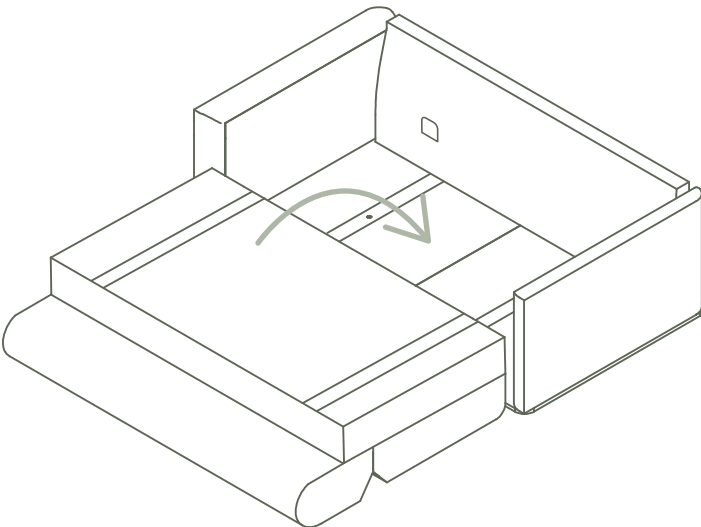

9. Fold up the mattress to convert the sofa bed into its seating position.

Click the button to watch the assembly video

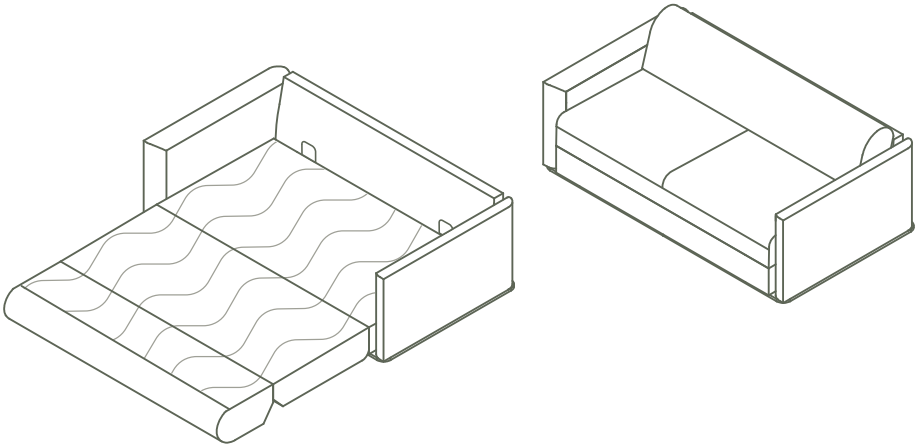

-
10. Add your backrest and armrest cushions.



Ensure backrest cushion tag is on outside

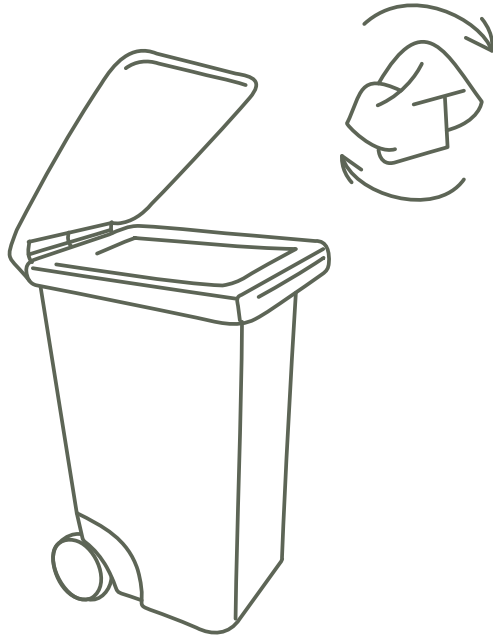

don't forget to recycle.

koala